



# PRESSURE SWITCHES

## ST/SG-02

### Threaded Connections/Sub-plate Mounting

PRESSURE  
CONTROLS

Up to 35 MPa (5100 PSI)

These pressure switches are used in hydraulic systems to make or break an electrical circuit at a preset hydraulic pressure. The pressure switch has two microswitches, each of which is capable of detecting electrically the high pressure or low pressure setting. The microswitch has a dust and drip-proof structure.



#### Specifications

Model Numbers		Max. Operating Pressure MPa (PSI)	Approx. Mass kg (lbs.)	
Threaded Connection	Sub-plate Mounting		ST type	SG type
ST-02-*20	SG-02-*20	35 (5100)	4.5 (9.9)	4.5 (9.9)
ST-02-*2080	SG-02-*2080			
ST-02-*2090	SG-02-*2090			

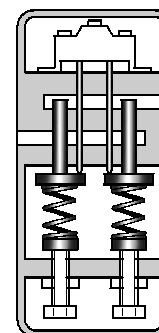

#### Micro Switch Ratings

Loads	AC		DC
	Normally Closed Contact	Normally Open Contact	
Inductive Load	4.5 A - 125V 3.0 A - 250V	2.5 A - 125V 1.5 A - 250V	0.05 A - 125V 0.03 A - 250V
Electric Motor, Incandescent Lamp, Electromagnetic Coil Load			—

Graphic Symbol

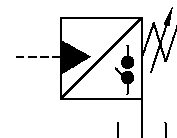

#### Model Number Designation

F-	S	T	-02	-B	-20	*
Special Seals	Series Number	Type of Mounting	Valve Size	Pres. Adj. Range MPa (PSI)	Design Number	Design Standards
<b>F:</b> Special Seals for Phosphate Ester Type Fluids (Omit if not required)	<b>S:</b> Pressure Switches	<b>T:</b> Threaded Connection	<b>02</b>	<b>B:</b> 0.7 - 7.0 (100 - 1020) <b>C:</b> 3.5 - 14 (510 - 2030) <b>H:</b> 7.0 - 21 (1020 - 3050) <b>K:</b> 10.5 - 35 (1520 - 5100)	<b>20</b>	<b>None:</b> Japanese Std. "JIS" <b>80:</b> European Design Std. <b>90:</b> N. American Design Std.
		<b>G:</b> Sub-plate Mounting			<b>20</b>	

#### Sub-plate

Valve Model Numbers	Japanese Standard "JIS"		European Design Standard		N. American Design Standard		Approx. Mass kg (lbs.)
	Sub-plate Model Numbers	Thread Size	Sub-plate Model Numbers	Thread Size	Sub-plate Model Numbers	Thread Size	
SG-02	SGM-02-20	Rc 1/4	SGM-02-2080	1/4 BSP.F	SGM-02-2090	1/4 NPT	1.1 (2.4)

● Sub-plates are available. Specify the sub-plate model number from the table above. When sub-plates are not used, the mounting surface should have a good machined finish.

#### ■ Attachment

##### ● Mounting Bolts

Valve Model Numbers	Socket Head Cap Screw		Qty.
	Japanese Std. "JIS" and European Design Std.	N. American Design Std.	
ST-02	M6 × 60 Lg.	1/4 - 20 UNC × 2-1/2 Lg.	2
SG-02			

#### ■ Hydraulic Fluids

##### ● Fluid Types

Any type of hydraulic fluids listed in the table below can be used.

Petroleum base oils	Use fluids equivalent to ISO VG32 or VG46.
Synthetic fluids	Use phosphate ester or polyol ester fluid. When phosphate ester fluid is used, prefix "F-" to the model number because the special seals (fluororubber) are required to be used.
Water containing fluids	Use water-glycol fluid.

Note: For use with hydraulic fluids other than those listed above, please consult your Yuken representatives in advance.

##### ● Recommended Viscosity and Oil Temperatures

Recommended Viscosity and Oil Temperatures

Viscosity ranging between 15 - 400 mm<sup>2</sup>/s (77 - 1800 SSU).

Oil temperatures between -15/+70°C (5 - 158°F).

Use hydraulic fluids which satisfy the recommended viscosity and oil temperatures given above.

##### ● Control of Contamination

Due caution must be paid to maintaining control over contamination of the hydraulic fluids which may otherwise lead to breakdowns and shorten the life of the valves. Please maintain the degree of contamination within NAS 1638-Grade 12. Use 25 μm or finer line filter.

#### ■ Instructions

##### ● Pressure adjustments

Remove the front cover and loosen the lock nut. Turn the pressure adjustment screw slowly clockwise to increase pressure or anti-clockwise to decrease pressure. After adjustment, be sure to tighten the lock nut and replace the front cover in the original position.

##### ● Drain piping

Connect the drain pipe not to any other line but directly to the tank.

##### ● Pressures and Microswitch contacts

Pressure	Contact Point	
	High Pressure Microswitch	Low Pressure Microswitch
Under the setting pressure		
Above the setting pressure		

##### ● Microswitch terminals

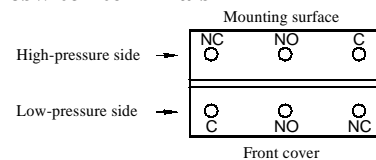

#### ■ Differential Pressure Characteristic

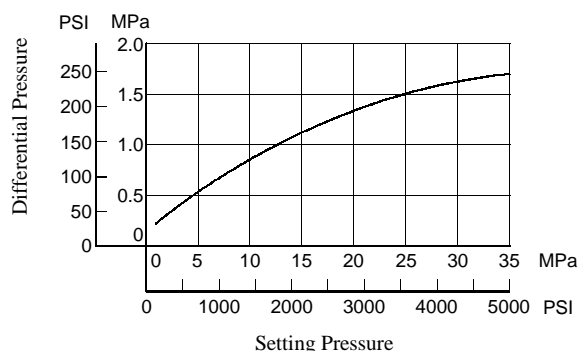

★ The differential pressure means the pressure difference caused between at NC and at NO when one of the pressures on the high and low pressure side is increased and then decreased.

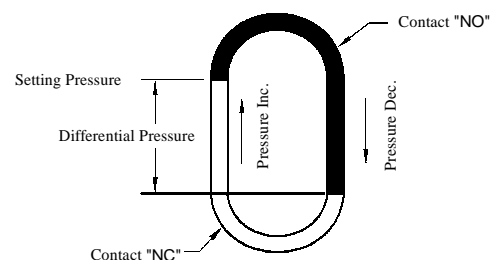

ST-02-\*\*-20/2080/2090

DIMENSIONS IN  
MILLIMETRES (INCHES)

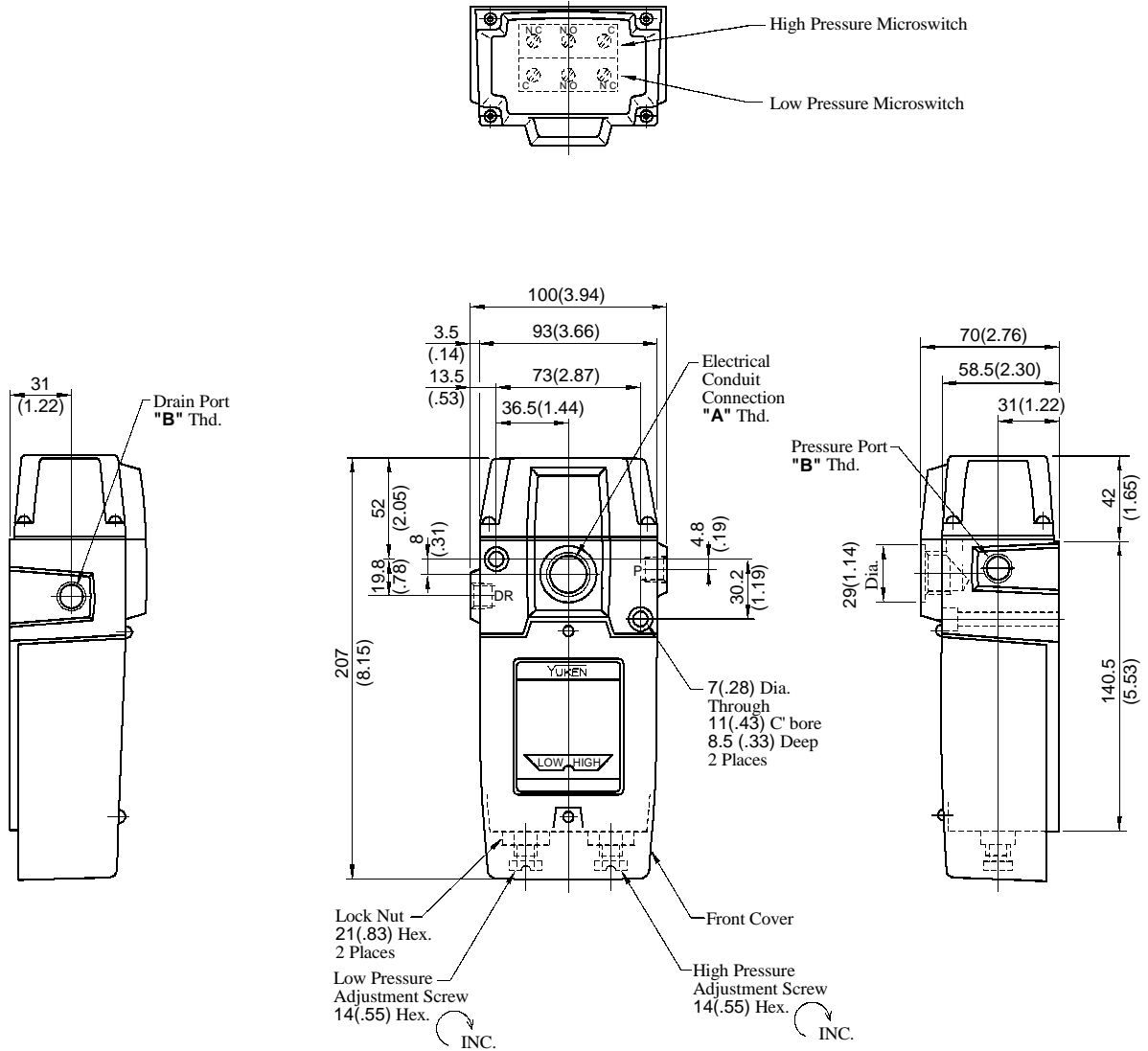

Model Numbers	"A" Thd.	"B" Thd.
ST-02-**-20	G 1/2	Rc 1/4
ST-02-**-2080	3/4 × 16 whit BS 31	1/4 BSP.F
ST-02-**-2090	1/2 NPT	1/4 NPT

SG-02-\*20/2080/2090

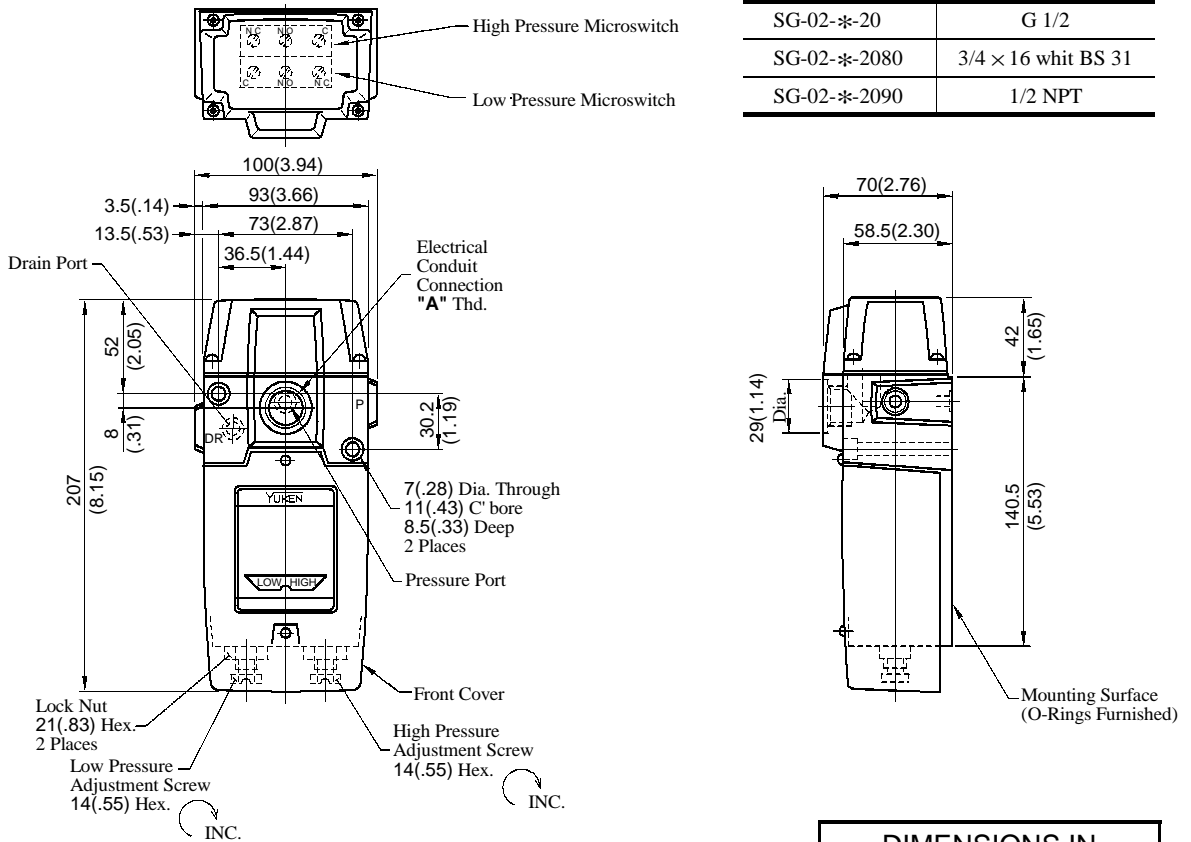

Model Numbers	"A" Thd.
SG-02-*20	G 1/2
SG-02-*2080	3/4 × 16 whit BS 31
SG-02-*2090	1/2 NPT

DIMENSIONS IN  
MILLIMETRES (INCHES)

Sub-plate : SGM-02-20/2080/2090

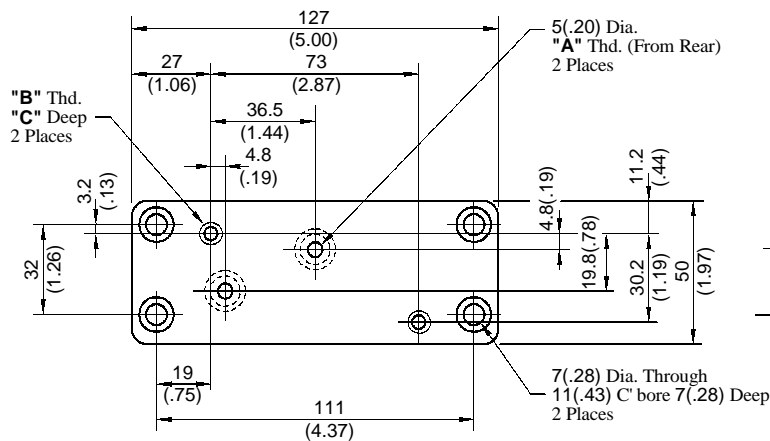

Sub-plate Model Numbers	"A" Thd.	"B" Thd.	"C" mm (Inches)
SGM-02-20	Rc 1/4	M6	12 (.47)
SGM-02-2080	1/4 BSP.F		
SGM-02-2090	1/4 NPT	1/4-20 UNC	16 (.63)



Examples	Schematic Diagram	Wiring Diagram
<p>Example 1 Solenoid is required to be energised at low pressure setting and de-energised at high pressure setting.</p>		
<p>Example 2 Solenoid is required to be de-energised at low pressure setting and energised at high pressure setting.</p>		
<p>Example 3 Electric motor is required to be started at low pressure setting and stopped at high pressure setting.</p>		

ST-02-\*20/2080/2090  
SG-02-\*20/2080/2090

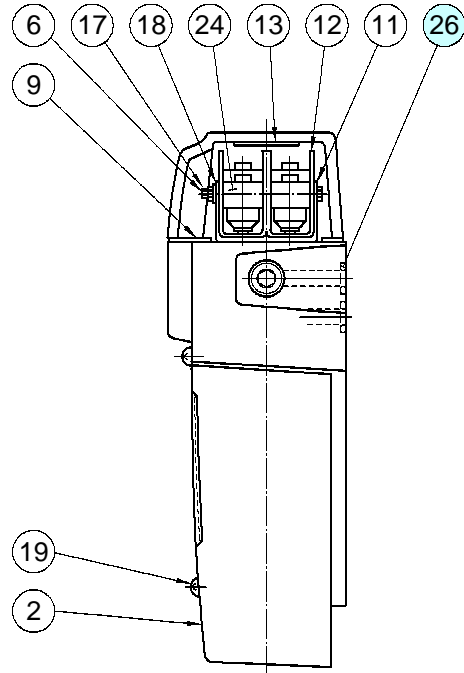
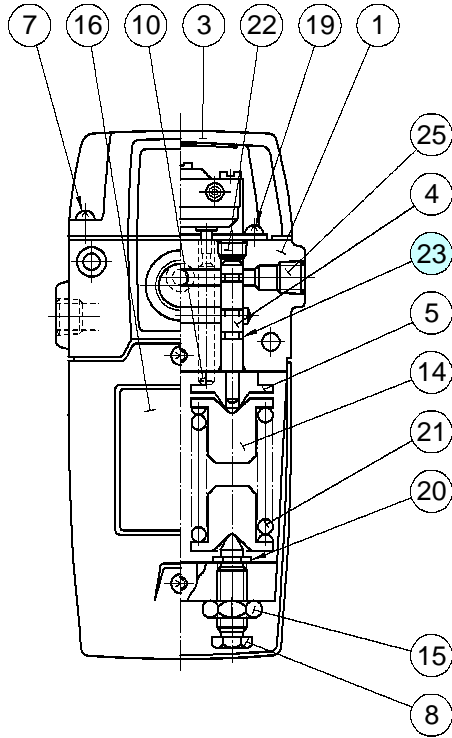

#### List of Seals

Item	Name of Parts	Part Numbers		Qty.
		ST-02	SG-02	
23	O-Ring	SO-NA-P5	SO-NA-P5	2
26	O-Ring	—	SO-NB-P8	2

Note: When ordering the seals, please specify the seal kit number from the table right.

#### List of Seal Kits

Model Numbers	Seal Kit Numbers
ST-02-*20/2080/2090	KS-ST-02-20
SG-02-*20/2080/2090	KS-SG-02-20